

Heat On Demand Advantage® Plus Induction Heating Activator Model ADV700

Aladdin's Heat On Demand Advantage® Plus induction heating activator revolutionizes kitchen operations, giving you features, performance and efficiencies other meal-delivery systems just can't deliver. Achieve long hot food holding times with or without a heated plate.^{1,2} Fast 12 second cycle delivers up to 5 trays per minute.



The prominent **LED status light** displays a different vibrant color at every stage.

HEAT ON DEMAND

Advantage **Plus**



MINUTES
HOLD TIME



SECONDS
CYCLE TIME

Heat On Demand Advantage® Plus Benefits

- Hot food for higher patient satisfaction scores.
- Time-tested design and component reliability.
- Less heating equipment for a cooler kitchen.
- Simple operation for greater employee satisfaction.
- No dish heater required for heating plates.²
- Industry-leading performance.

Performance

- When using a heated plate and Aladdin Radiance® dome, Heat On Demand Advantage Plus maintains food temperatures at or above 140°F (60°C) for 85+ minutes¹, and for 66+ minutes² without using a heated plate.
- 12-second heating cycle, activates up to 5 bases per minute.
- Bases stay cool to the touch and fit standard 9" entrée plates.

Construction

- Durable stainless steel countertop design.
- Solid-state electronic controls for enhanced reliability.
- Robust polymer centering guide for hassle-free base insertion and removal.
- Designed for use in commercial kitchens.

Standard Features

- New LED status light signals cycle change (white / idle; red / heating; green / ready; yellow / error).
- Automatic voltage calibration adjusts activator settings for 208 to 240 volt power.
- Cycle time not affected by voltage fluctuations.
- Error prevention logic eliminates the guesswork.
- Visual and audible indicators alert when the base is ready.
- Energy saving automatic shut-off.
- Internal fans keep electronics cool during heavy use.
- Base and activator diagnostics.
- Easy to remove washable air filters.
- Easy to clean.



Sustainability

Efficient induction technology provides significant energy savings.

- 78% - 82% energy savings³ as compared to a system requiring a convection heated base and plate, depending on the number of meals served per serving period.
- 57% energy savings³ as compared to a system requiring a convection heated plate and an induction heated base.

Heat On Demand Advantage® Plus Induction Heating Activator Model ADV700

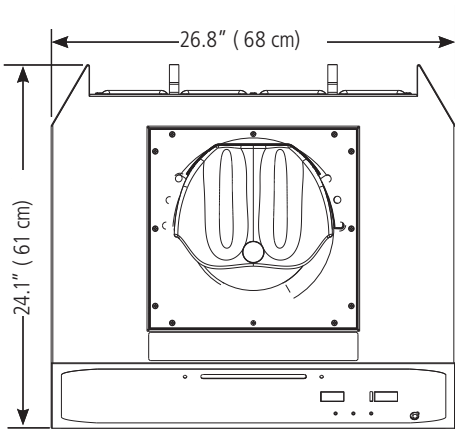

Plan View

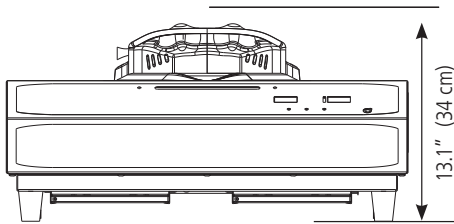

Front Elevation

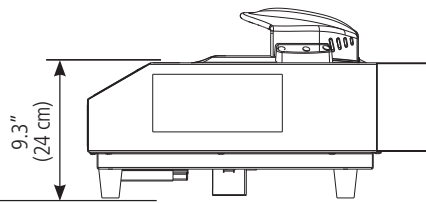

Side Elevation

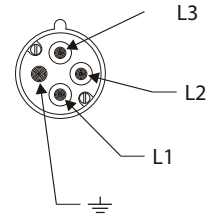

430P9W
Pin and
Sleeve Plug

Advantage Plus System

Activates Advantage (IHB26) bases which accommodate standard 9" (23 cm) dishware.

Visit aladdintemprite.com to see all Advantage base color options.

Heat On Demand Advantage® bases stay cool on the sides, so they're safe to handle without gloves or a base lifter, and they're safer for patients and residents, too. They accommodate standard 9" (22.86 cm) dishware and domes.

Use only with Aladdin Heat On Demand Advantage® bases.

Heat on Demand Advantage® Plus Technical Specifications

Model Number	Electrical ⁴	Cord Set/ NEMA Plug ⁴	Width	Depth	Height	Weight	Shipping Weight
<input type="checkbox"/> ADV700 208-240v model	Volts: 208-240 volt Hertz: 60 Phase: Three Max amp draw: 23.5 Min. amp capacity: 30	430P9W 5.5' (167.6 cm) cord with pin and sleeve plug	26.8" (68 cm)	24.1" (61 cm)	13.1" (34 cm)	61 lbs. (28 kg)	78 lbs. (35 kg)

¹11-oz. (311 grams) of food input at 165°F (74°C) with a 165°F (74°C) heated plate, Aladdin Radiance™ dome (73+ minutes hold time with other Aladdin domes).

²11-oz. (311 grams) of food input at 165°F (74°C) without a heated plate, Aladdin Radiance™ dome (60+ minutes hold time with other Aladdin domes).

³Energy savings calculations will vary based on exact equipment mix and local energy rates. Percentage savings based on using an ambient plate.

⁴Unit should be operated on a 30-amp dedicated circuit. Wall or raceway receptacle number 430R9W; drop cord connector number 430C9W.

Complies with: Title 47, section 18, FCC; and Title 29, section 1910.97, OSHA.



FOR SERVICE AND
WARRANTY
INFORMATION

ADV700:
1 YEAR, Parts and Labor
Centering Guide:
2 YEARS Parts



Visit aladdintemprite.com/patents for patent information.

250 E. Main St. | Hendersonville, TN 37075 | Customer Service: 800.888.8018 | Tech Service: 800.888.5426 | Fax: 888.812.9956 | aladdintemprite.com

©2021 Aladdin Temp-Rite.® All rights reserved. Note: Specifications are subject to change without notice.



S211022ADV700 Rev-1